

NOTES FOR CONCRETE SLABS

- Dimensions should be taken from architectural plan except for foundation components.
- Reinforcing to be continuous around the building as shown. Minimum lap of reinforcing at splices – 18". No gaps in the reinforcing will be permitted, unless specifically designed. Use Grade 60 steel.
- All Reinforcing Steel to be properly tied and supported using chairs or approved devices.
- Bends in reinforcing bars shall not be smaller than 6 bar diameter on the inside radius.
- All backfill shall be compacted to a minimum of 90% of the soils maximum Modified Proctor dry density, ASTM D-1557. The only exception to this will be components of any peripheral drain.
- Excavation shall be observed by Geotechnical Engineer to determine if soils over the building area are the same as those for which the building was designed.
- Reinforcing shall be observed by engineer prior to placing concrete. Structure will be reinforced as shown on plans. No changes in building loads, reinforcing or design shall be made after final inspection.
- Open-graded gravel pad should not be used beneath slab unless well drained.
- Do not use dry wells on site, unless sited and approved by Geotechnical Engineer.
- Foundation concrete shall have a minimum strength of 3000 psi placed with a maximum slump of 5 inches. It shall be made using "Modified" Type II Cement or equal protection, with no Calcium Chloride added.
- Separate interior and exterior slabs from all structural portions of building with expansion joint or folded polyethylene film.
- Prior to backfilling procedures, foundation walls should be allowed to cure a minimum of 7 days and be adequately supported by floor systems or other bracing.
- Refer to the soils letter for peripheral drain recommendations.
- *Water shall not be allowed to stand or pond within 15' of the building during or after construction, except at specific direction of the Geotechnical Engineer. Backfill shall not be flooded, soaked or jetted during or after construction.*
- *Roof drains shall be carried away from the building at least 5' past any backfill and not allowed to soak the foundation soils.*
- *UNDERGROUND PIPING MAY BE REQUIRED TO PROPERLY REMOVE ROOF DOWNSPOUT DISCHARGES.*
- *Planters, if any, should be well-sealed and drained.*
- *Surface drainage should be positive and rapid in all directions away from the building at all points. The yard within 10' of the structure and all backfill to be sloped away from the structure at a minimum gradient of 8%.*

NOTES FOR STRUCTURAL FILL, AS REPLACEMENT

- THE UPPER 24" OF THE SOILS BELOW THE FOUNDATION ELEMENTS ARE TO BE REMOVED & REPLACED WITH A FILL COMPACTED ACCORDING TO THESE SPECIFICATIONS. Soil moisture conditioning to 48" (min.) below Foundation Elements.
- The open excavation is to be closely examined by a representative of the Geotechnical Engineer for adequate over-excavation and exposure of proper bearing soils. As required by the Engineer, the upper 8" of the subgrade soils are to be moisture-conditioned and compacted to a minimum of 90% of the soils maximum Modified Proctor Dry Density (ASTM D-1557.)
- AT THE DIRECTION OF THE GEOTECHNICAL ENGINEER, the over-excavation is to be water soaked for two (2) days minimum.
- WATER MUST PENETRATE a minimum of 24" BELOW THE OVEREXCAVATION. Multiple applications of water will be required.
- Replace ANY and ALL Soft or Unsuitable soils with preapproved native non-expansive soils or import a coarse-grained, non-expansive, non-freedraining, man-made structural fill and place in the overexcavated portion of the site.
- The upper 6" to 12" of the fill is to be a sandy gravel (-3/4" & GM/GW) or a gravelly sand (-3/4" & SM/SW.)
- Place structural fill in lifts not to exceed 6 inches after compaction.
- The structural fill should be compacted to a minimum of 90% of the soils maximum Modified Proctor dry density (ASTM D-1557) and placed at a moisture content conducive to the required compaction (Proctor optimum moisture ±2%.)
- The structural fill must be brought to the required density by mechanical means. No uncontrolled soaking, jetting or puddling techniques should be used during compaction, unless specifically directed by the Geotechnical Engineer.
- Surface density tests should be taken at maximum 2 foot intervals to confirm the quality of the compacted fill product.

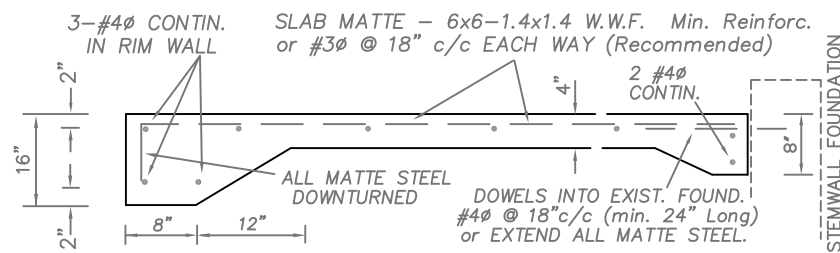

PORCH / PATIO – SLAB EDGE SECTION
MUST BE UNDERLAIN WITH STRUCTURAL FILL.

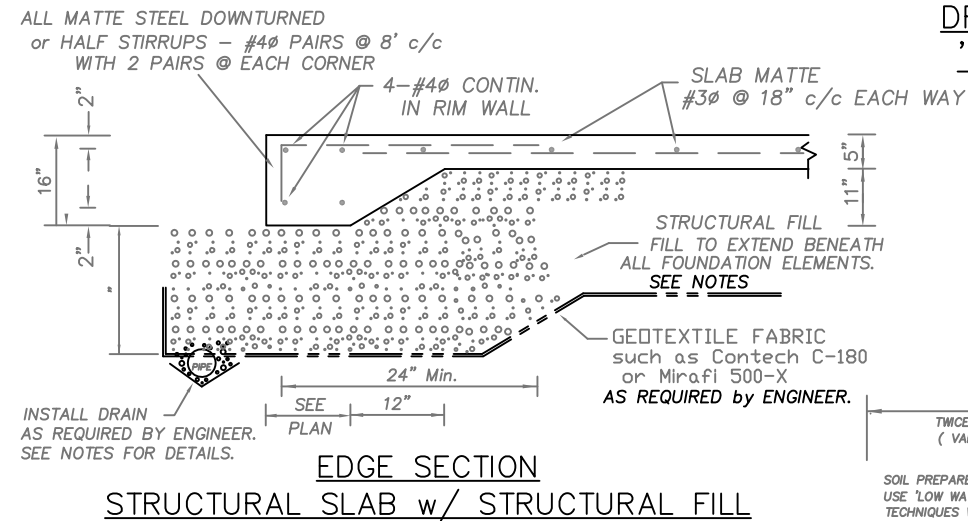

EDGE SECTION
STRUCTURAL SLAB w/ STRUCTURAL FILL

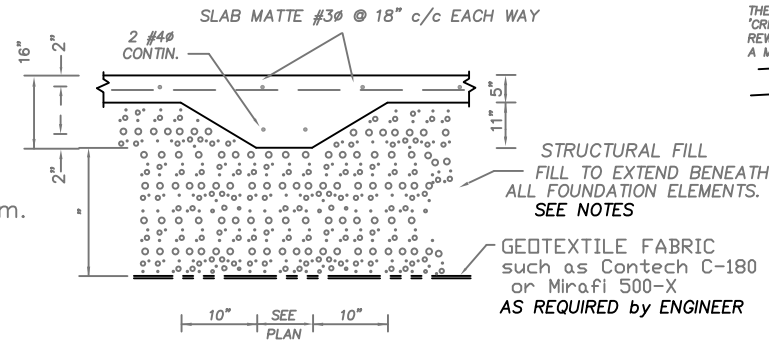

INTERIOR BEARING WALL SECTION
STRUCTURAL SLAB – STRUCTURAL FILL

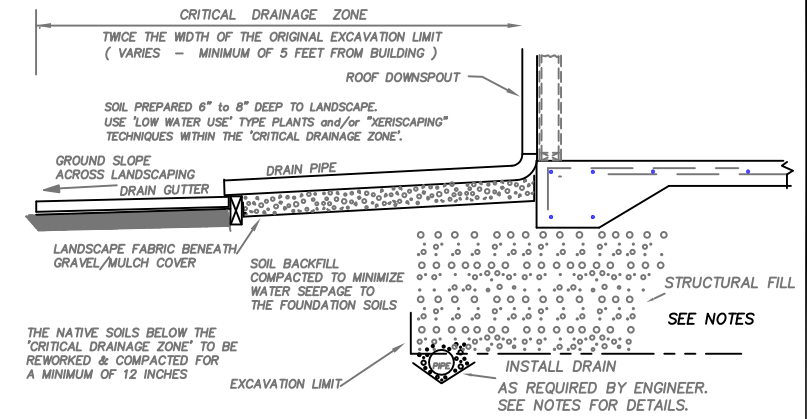

DRAINAGE / LANDSCAPING CONCEPT
'NO WATER ZONE' BY FOUNDATION

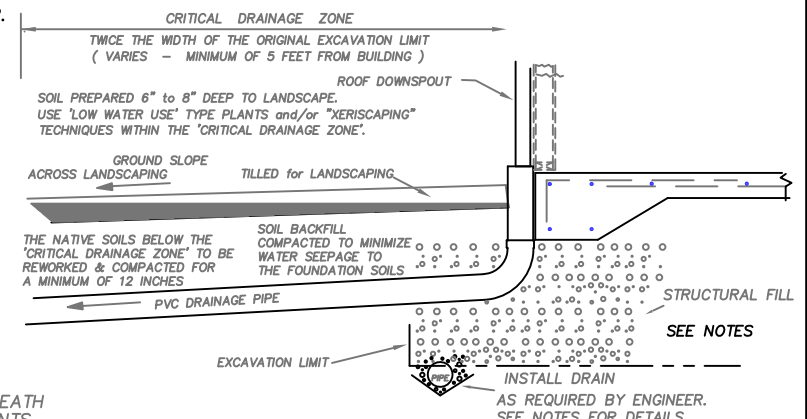

DRAINAGE / LANDSCAPING CONCEPT
'LOW WATER ZONE'

ENGINEERS' CERTIFICATE:

I HEREBY CERTIFY THAT THIS FOUNDATION DESIGN WAS PREPARED BY ME or UNDER MY DIRECT SUPERVISION.

By:

EDWARD M. MORRIS, Registered Professional Engineer
State of Colorado – Number 30590

Soil Type: ALLUVIAL SILTY CLAY, LEAN CLAY & SILT
24" STRUCTURAL FILL (12" Native + Import)
Soil Bearing: 2000 psf Maximum, 150 psf Minimum

FOUNDATION DESIGN – HORNET-GR MODEL
BUTTNER Sub., Grand Junction
HRWC, GRAND JUNCTION, COLORADO



GRAND JUNCTION LINCOLN DeVORE

2191 CANYON COURT W.
GRAND JCT., COLORADO, 81507
970-260-3332 email- gjldem@earthlink.net

JOB #	952-GJ	SHEET	2	OF	2
DRAWN BY:	E. M. MORRIS	SCALE:	NO SCALE	DATE:	1-17-2017
CHECKED BY:	E. M. MORRIS	FILE #	HRWC-HR	REV.	.